



## COMMERCIAL REAR CONTROL SINGLE DRYER

With a large load capacity in a compact frame, each one of our single dryers is all business, all the time. This Huebsch dryer features an easy-to-clean lint compartment and the industry's largest door opening (2.06 sq ft, 1,913.8 sq cm) for faster loading and unloading. Huebsch single dryers are designed to suit your needs.

### Built for Reliable Performance

Huebsch®'s dryer, defined by its simplicity and its performance, provides everything you need to get the job done - and nothing you don't. Huebsch's single load dryers combine heavy-duty construction with reliable operation proven to stand the test of time. They're designed with less moving parts for one reason: so you'll face fewer maintenance problems and less wear and tear down the road. Huebsch's dryers provide the perfect balance of heat, airflow and tumble action for optimal performance and efficiency.

- Integrated meter case
- Industry's largest door opening 2.06 sq. ft. (1914 cm<sup>2</sup>)
- Quiet, efficient blower system
- Door is reversible for installation flexibility
- High efficiency exhaust blower with superior airflow 220 cfm (105 liters/sec)
- 100% serviceable from the front
- Space-saving narrow cabinet 26.875" (683 mm)
- Upfront lint filter easy to clean and secured
- Durable galvanized steel cylinder
- Large capacity meter case standard



### MDC

"MDC" MICRO - Our Micro-Display Control (MDC) clearly displays the vend price and keeps customers informed throughout the drying process with cycle status lights and a digital cycle countdown. Interfacing with a variety of aftermarket card reader systems, coin mechanisms and central payment systems, MDC offers many cycle selections and basic audit features.

# COMMERCIAL REAR CONTROL SINGLE DRYER

## SPECIFICATIONS

MODEL - see below for all models and activation available		
CONTROL OPTION	MDC	
COLOR	White	
CAPACITY - lb (kg)	18 (8.2)	
OVERALL WIDTH - in (mm)	26.875 (683)	
OVERALL DEPTH - in (mm)	28 (711)	
OVERALL HEIGHT - in (mm)	43 (1092)	
CYLINDER VOLUME - cu. ft. (liters)	7.0 (198)	
MOTOR (THERMAL PROTECTED)	0.33 HP	
TYPE OF GAS (GAS MODELS ONLY)	Factory equipped natural	
AIR OUTLET DIAMETER - in (mm)	4 (102)	
EXHAUST AIRFLOW - cfm (liters/sec)	220 (105)	
AVAILABLE CYCLES	High, Medium, Low, Delicates, No Heat	
ELECTRICAL REQUIREMENTS	Gas	220-240/50/1
HEATING ELEMENT	Gas	25,000 Btu
NET WEIGHT - lb (kg)	Gas	150 (68)
SHIPPING WEIGHT lb (kg)	Gas	161 (73)
SHIPPING DIMENSIONS APPROX. - in (mm)	Width	30.5 (775)
	Depth	29.5 (749)
	Height	45 (1143)
AGENCY APPROVALS	Gas	cCSAus

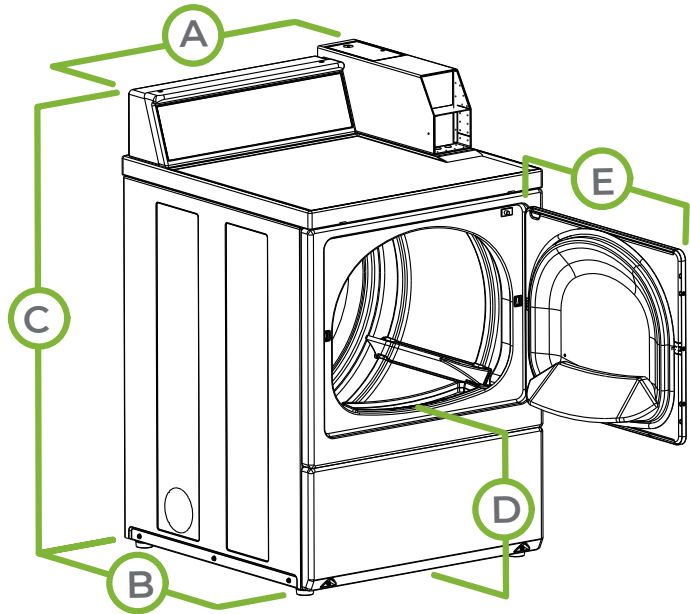

A.	OVERALL WIDTH - in (mm)	26.875 (683)
B.	OVERALL DEPTH - in (mm)	28 (711)
C.	OVERALL HEIGHT - in (mm)	43 (1092)
D.	FLOOR TO DOOR OPENING -in (mm)	15.44 (392)
E.	DOOR SWING - in (mm)	23.5 (597)

MODELS	VOLTAGE/FREQ/PH		ACTIVATION
HDGBXRG303NW21	220-240/50/1	Gas	Prep for Coin 

ADA Compliant

Note: Not all options are available for all models. Refer to the price list for the available models and options. Twelfth digit in model number indicates US or Canadian unit. C=Canada and T=US.

\* Information shown applies to highest end control available.

For the most accurate information, the installation guide should be used for all design and construction purposes. Due to continuous product improvements, design and specifications subject to change without notice. The quality management system of Alliance Laundry Systems has been registered to ISO 9001.